



-05

# MTT13 CAT773(F) Scheduled/Special Inspections & Recommended Support Parts

*SPECIALTY HAULAGE SOLUTIONS FOR MINING AND CONSTRUCTION*



**MEGA CORP.®**

700 Osuna Rd. N.E. • Albuquerque, NM 87113 • 1-800-345-8889 • 505-345-2661 • Fax 505-345-6190  
[www.megacorpinc.com](http://www.megacorpinc.com)

© 2011 MEGA Corp., Inc. All Rights Reserved

# TABLE OF CONTENTS

Supersedes 22 Dec 2009

	Page
Section 1. Definitions and Abbreviations .....	1-1
Section 2. Scheduled Inspections .....	2-1
Section 3. Special Inspections .....	3-1
Section 4. Recommended Support Parts .....	4-1



**MTT13-CAT773(F)-5**  
**22 Apr 2011**

## **TABLE OF CONTENTS**

# SECTION 1

## Definitions and Abbreviations

Warning, Cautions & Notes .....	1-1	Abbreviations .....	1-5
Shall, Will, Should and May .....	1-1	MTT13 General Overview .....	1-6
Safety Messages .....	1-2		

### MANUAL USAGE

This technical manual only contains information required to safely install the MTT on the CAT 773F. See the CAT 773F Maintenance and Operators Safety Manual for specific vehicle system information and maintenance procedures. The exact location of the hazards and description of the hazards are reviewed in this section. All personnel working on or operating the MTT must become familiarized with all the safety messages.

If your system is not covered in this manual please contact MEGA Corp. Product Support Group at:

US toll free: 1-800-345-8889

Direct: 1-505-345-2661 or visit our website at [www.megacorpinc.com](http://www.megacorpinc.com) for more detailed contact information.

See the proper manufacture specific Operation & Maintenance, Safety Manuals and Service Manuals for detailed chassis specific system information and chassis specific maintenance procedures.

### ⚠ WARNING

Due to the nature of these processes, ensure that all safety information, warnings and instructions are read and understood before any operation or any maintenance procedures are performed. Some procedures take place with heavy components and at moderate heights, ensure proper safety procedures are maintained when performing these actions. Failure to use and maintain proper safety equipment and procedures will cause injury, death or damage to equipment.

### WARNING, CAUTION AND NOTES

The following definitions are found throughout the manual and apply as follows:

#### ⚠ WARNING

Operating procedures and techniques, which could result in personal injury and/or loss of life if not carefully followed.

#### CAUTION

Operating procedures and techniques, which could result in damage to equipment if not carefully followed.

#### NOTE

Operating procedures and techniques that are considered essential to emphasis.

### USE OF SHALL, WILL, SHOULD AND MAY

**Shall and Will** – Used when application of a procedure is mandatory.

**Should** – Used when application of a procedure is recommended.

**May** - Used to indicate an acceptable or suggested means of accomplishment.

## SECTION 1

### Definitions and Abbreviations

#### SAFETY MESSAGES

There are several specific safety messages on this machine. The exact location of the hazards and description of the hazards are reviewed in this section. All personnel working on or operating the machine must become familiarized with all the safety messages.

Make sure that all of the safety messages are legible. Clean the safety messages or replace the safety messages in you cannot read the words. Replace the illustrations if the illustrations are not legible. When you clean the safety messages, use a cloth, water and soap. Do not use solvent, gasoline or other harsh chemicals to clean the safety messages. Solvents, gasoline or harsh chemicals could loosen the adhesive that secures the safety messages. Loose adhesive will allow the safety messages to detach.

Replace any safety message that is damaged or missing. If a safety message is attached to a part that is replaced, install a new safety message on the replacement part.

#### Toxic Gas Hazard (1)

This safety label is located on the side of the tank and at all water fill entrances.

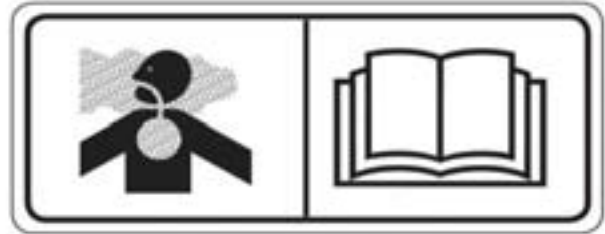

#### **⚠ WARNING**

**Cutting or welding operation on the inside of the tank can cause the accumulation of toxic gases. Read and understand instructions and warnings in the Maintenance Manual. Failure to provide proper ventilation or breathing apparatus while conducting these operations may result in serious injury or death.**

#### Do Not Operate (2)

This safety label is located on the outside of the front and rear control boxes. (If equipped)



#### **⚠ WARNING**

**Do not open this control box unless you read and understand the instructions and warnings in the Operator and Maintenance Manual. Failure to follow instructions or heed the warnings could result in serious injury or death.**

## SECTION 1 Definitions and Abbreviations

### Backing Runover Hazard (3)

This safety label is located on the rear of the tank and inside the cab.

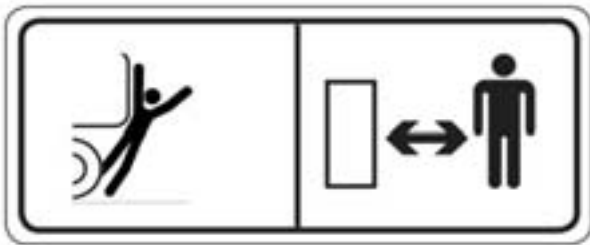

**⚠ WARNING**

The vehicle is equipped with a back-up alarm. Alarm must sound when operating this vehicle in reverse. Failure to maintain a clear view in the direction of travel could result in serious injury or death.

### Freezing (4)

This safety label is located on the side of the tank, at the sump drain, and on the pump.

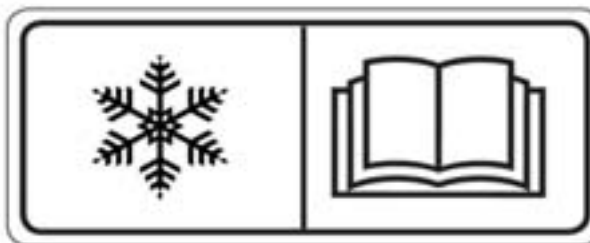

**⚠ WARNING**

Drain tank, fill pipe and valve in freezing weather. Refer to the Operator and Maintenance Manual for the procedure to follow.

### Non-Potable (5)

This safety label is located on the side of the tank and sump drain.



**⚠ WARNING**

Water held within tank is not potable. Do not use tank for transport of water intended for human or animal consumption or serious injury or death may result.

### Do Not Hoist While in Motion (6)

This safety label is located inside the cab.



**⚠ WARNING**

Do not engage hoist cylinders while vehicle is in motion. Before engaging hoist STOP the vehicle. Do not engage hoisting cylinders unless you read and understand the instructions and warnings in the Operator or Maintenance Manual. Failure to follow instructions or heed the warnings will result in injury or death.

## SECTION 1 Definitions and Abbreviations

### Fall Hazard (7)

This safety label is located at the top of the front and rear of the tank.



**⚠ WARNING**

Do not walk on the top of tank without fall arrest PPE. Serious injury or death could occur from a fall.

### Rotating Shaft (8)

This safety label is located on the pump.

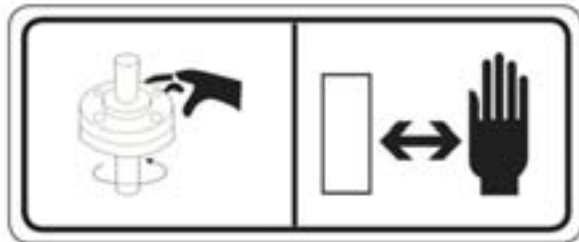

**⚠ WARNING**

Do not place your hand or tools within pump bell while pump is rotating and/or pressure held within the motor supply hose. Refer to the Operator and Maintenance Manual for the procedures to operate and maintain the pump. Failure to follow proper procedures could result in serious injury.

### High Pressure Sprayheads (9)

This safety label is located on the spraybar.

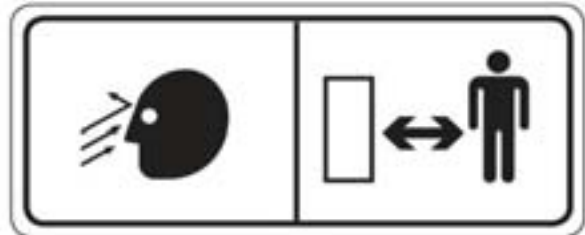

**⚠ WARNING**

Do not operate sprayheads until all personnel are a safe distance away from the vehicle.

### High Pressure Monitor (10)

This safety label is located on top of the cab control box.

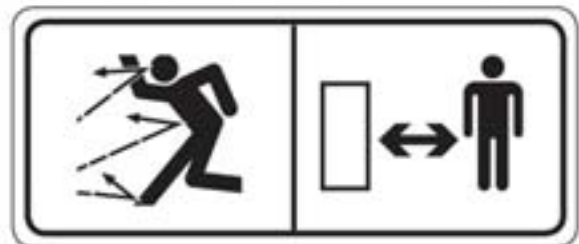

**⚠ WARNING**

Do not operate the monitor until all personnel are a safe distance away from the vehicle.



## SECTION 1

### Definitions and Abbreviations

#### High Pressure Motor (11)

This safety label is located on the hydraulic motor.

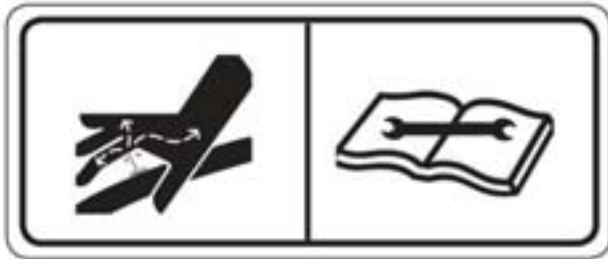

**⚠ WARNING**

**Hydraulic motor and supply lines contain oil under high pressure. Improper removal and repair procedures could cause severe injury. To remove or repair, instructions in the Maintenance Manual must be followed.**

#### ABBREVIATIONS

- BFV – Butterfly Valve
- CCW – Counter Clockwise
- CW - Clockwise
- FT - Feet
- FPM – Feet Per Minute
- GPM – Gallons Per Minute
- IN/SQ FT – Inches per Square Feet
- KM-H – Kilometers Hour
- Kg – kilograms
- l - liters
- LT – Left
- m - meters
- MPH – Miles Per Hour
- MTT – Mega Truck Tank
- psi - pounds square inch
- RPM – Revolutions Per Minute
- RT – Right
- SQ FT – Square Feet
- VDC – Volts Direct Current

#### Confined Space (12)

This safety label is located near water tank access and fill ports.



**⚠ WARNING**

**Do not enter confined spaces without following established site specific procedures. Failure to follow proper safety procedures will result in serious injury or death.**

# SECTION 1

## Definitions and Abbreviations

### MTT 13/15 OVERVIEW

REAR  
VIEW

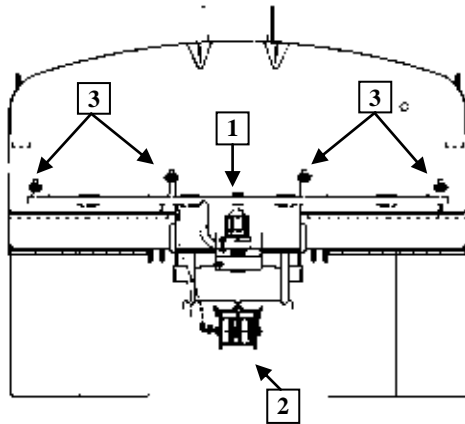

TOP  
VIEW

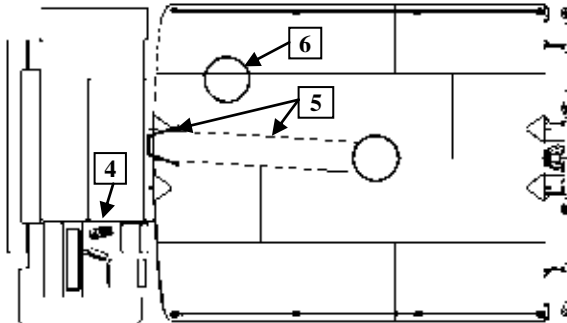

SIDE  
VIEW

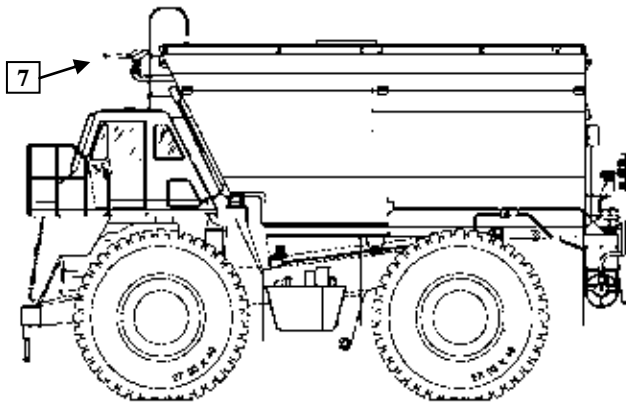

- 1** WATER PUMP & HYDRAULIC MOTOR
- 2** HOSE REEL
- 3** SPRAY HEADS
- 4** CAB CONTROL
- 5** HAND RAIL & WALKWAY
- 6** FOAM CONCENTRATE TANK
- 7** MONITOR

## SECTION 2 Scheduled Inspections

### Contents

Description .....	2-1	MTT Structure .....	2-2
Sprayheads .....	2-1	Water Pump System .....	2-3
Control System .....	2-2		

#### DESCRIPTION

This section establishes scheduled maintenance inspections of the installed MTT at the designated frequencies. Performing these inspections will identify potential system discrepancies and allow preventative maintenance to be performed before a component or system is rendered totally inoperative.

**\*\*NOTE:** Vehicles operated in extremely low quality water environments may require more frequent inspections.

		FREQUENCY					
SPRAYHEADS		WEEKLY (150 HRS)	BI- WEEKLY (250 HRS)	MONTHLY (500 HRS)	QUARTERLY (1000 HRS)	SEMI- ANNUAL (2500 HRS)	ANNUALLY (5000 HRS)
STEP							
1	Check spray head for damage and clean deflector ring and spray head opening.	X					
2	Check hydraulic lines for security, damage and leaks.	X					
3	Check spray head drop-in assembly for leaks with spray head switch OFF and water pump ON. Replace drop-in assembly as required.			X			
4	Check spray head base plate and upper housing mount bolts for security.			X			
5	Check spray head adjustable deflector ring for damage and correct adjustment. Apply dry-film lubricant to the deflector inner ring.			X			
6	Check spray head base plate for evidence of leaks. Replace base plate O-ring as required.						X

## SECTION 2 Scheduled Inspections

		FREQUENCY					
STEP	CONTROL SYSTEM	WEEKLY (150 HRS)	BI-WEEKLY (250 HRS)	MONTHLY (500 HRS)	QUARTERLY (1000 HRS)	SEMI-ANNUAL (2500 HRS)	ANNUALLY (5000 HRS)
1	Check all electrical cables for security and damage. Clean Deutsch connectors as required.			<b>X</b>			
2	Check all hydraulic solenoids and hosing for security and leaks.				<b>X</b>		
3	Check monitor/nozzle assembly for security leaks and condition. Repair as required.				<b>X</b>		
4	Check foam agent supply hoses and shut-off valve for security condition and evidence of suction leaks.				<b>X</b>		
5	Check all in-cab control functions for proper operation. Repair and replace control components as required.				<b>X</b>		
6	Check all in-cab control functions for proper operation. Repair and replace control components as required.				<b>X</b>		
7	Check hose reel for security mounting and leaks.			<b>X</b>			
8	Unreel the entire length of hose, pressurize hose and check hose and nozzle for security, wear and leaks.						<b>X</b>
STEP	MTT STRUCTURE						
1	Check filler port trash screen for debris and inspect assembly for security and damage. Repair or replace trash screen as required.	<b>X</b>					
2	Visually inspect tank exterior for damage and evidence of leaks. Repair as required			<b>X</b>			
3	Drain tank and remove water pump sump access cover. Remove trash and inspect sump area for damage.			<b>X</b>			
4	Check all lights (turn signal, brake, backing, parking, clearance and work) for proper operation. Replace lights as required.			<b>X</b>			
5	Check all interior tank structure for leaks, cracks and condition of epoxy coating (if equipped). Repair structure and coatings as required.					<b>X</b>	

## SECTION 2

### Scheduled Inspections

STEP	M-4 WATER PUMP SYSTEM	150 HRS (WEEKLY)	250 HRS (BI- WEEKLY)	500 HRS (MONTHLY)	1,000 HRS (QUARTERLY)	5,000 HRS (ANNUALLY)
1	Remove water pump from unit and check: water pump impeller retaining bolt/nut for security and for damage or contact to the impeller, impeller keyways for wear and security, shaft bearings for signs of heating and wear, drive end shaft keyways for signs of damage and heating and seals for security, damage and over or under lubrication. Check volute case for damage or contact. Check both of the impeller wear rings for damage and excessive wear (0.020" or 0.5 mm nominal tolerance) Check packing mount for security. (Disassembly of water pump is required to perform these maintenance operations). Repair as required.					<b>X</b>
2	Check shaft seals for excessive lubricant leakage and water leakage. Lubricate water pump with a <b>manual</b> grease gun only. When lubricating the drive motor side shaft bearing apply only 16 to 20 squirts (injections) of grease (2 fl. oz. or 60 cc) and 8 to 10 squirts (injections) of grease (1 fl. oz. or 30 cc) to the impeller end bearing. Apply 4 or 5 squirts (injections) of grease to lantern ring grease fitting. Adjust, repair or replace as required.				<b>X</b>	
3	Check water pump and drive motor for leaks, excessive vibration/noise leaks and evidence of excessive heating. Repair as required.	<b>X</b>				
4	Check rope seals for excessive water leakage, compression, wear and overheating. Adjust rope packing seal packing gland or replace rope packing seals as required.	<b>X</b>				
5	Check water pump inlet and discharge piping for security, leakage and misalignment. Repair leaks as required.				<b>X</b>	

**SECTION 2**  
**Scheduled Inspections**

## SECTION 3 Special Inspections

### Contents

Description .....	3-1	Cold Weather Operation and Storage .....	3-1
Fire Suppression System .....	3-1		

---

#### DESCRIPTION

This section contains special inspection requirements for a specific system after use, an unusual event or storage.

#### FIRE SUPPRESSION SYSTEM

##### AFTER USE

1. Flush foam concentrate supply hose, monitor and nozzle with fresh water.
2. Inspect foam concentrate hose for signs of collapsing, kinks, wear or leaks.
3. Wash down all MTT and vehicle surfaces that were exposed to the foam or foam concentrate.

#### COLD WEATHER OPERATION AND STORAGE.

##### CAUTION

Ice will cause serious damage to water pump, spray heads, butterfly valves and the monitor if water is allowed to remain in the volute case, water piping or on top of a closed butterfly valve and freeze. Ensure all water is drained from system when the temperatures are expected to fall below freezing for any period of time. Failure to ensure all systems are drained and free from standing water will result in shaft, operator, diaphragm, drive motor, water pump or butterfly valve damage when operation is attempted with ice in the housings.

To ensure all water is drained from tank check the following;

1. Park unit on a slight angle to allow water to flow to the rear of the tank.

2. Observe water level gauge, when it indicates EMPTY open spray bar petcocks and drain valves.
3. Open petcock on water pump volute case.
4. Remove sump cover.

##### NOTE

Take note when removing sump cover, the sump will contain water. When cover is removed water will leak from the access hole. Take an out of the way position to prevent the splashing of water and debris that may be within the sump and wetting the individual that removes the cover.

5. If unit is equipped with a hydraulic spray system, turn system ON.

##### CAUTION

Engaging/disengaging the water pump above LOW IDLE may result in water pump component damage and reduced service life.

6. Turn pump ON, keep engine at low idle.
7. Turn monitor ON.
8. Turn dump bar ON.
9. Turn drain ON.
10. Park monitor nozzle DOWN.
11. If unit is equipped with a pneumatic spray system, turn system ON.
12. Park monitor nozzle DOWN.

## SECTION 3

### Special Inspections

13. Turn monitor ON.
14. Turn dump bar ON.
15. Turn drain ON.
16. Turn pump OFF.

#### CAUTION

Engaging/disengaging the water pump above LOW IDLE may result in water pump component damage and reduced service life.

17. Turn system OFF.
18. If equipped with a pneumatic spray system, drain water separator filter inside solenoid control box.
19. If unit is equipped with a suction loading station, ensure volute case petcock is OPEN.
20. If unit is equipped with front spray bar, ensure spray bar drain is OPEN and water is not left in hose.
21. If unit is equipped with a hose reel, unroll hose, adjust discharge nozzle to OPEN, turn hose reel gate valve(s) ON, allow water to drain from hose and rewind.
22. Check to ensure all water has drained from tank.

#### To restore unit to service from drained storage;

1. Lubricate water pump bearings as instructed in -2 manual. Inject 2 oz. of grease in each water pump shaft bearing grease fitting and 4 to 5 injections of grease to lantern ring grease fitting.

2. Inspect tank interior to ensure it is clean, if the tank is coated, ensure coating integrity, clean or repair as required.
3. Install sump cover with new gasket.
4. Ensure water separator filter drain is closed if equipped.
5. Remove and clean hydraulic solenoid control box filter before operating machine.
6. Start engine.
7. Turn system ON.
8. Turn pump ON.

#### CAUTION

Engaging/disengaging the water pump above LOW IDLE may result in water pump component damage and reduced service life.

9. Ensure all sprayhead controls are OFF.
10. Turn dump bar OFF.
11. Turn drain OFF.
12. Turn monitor OFF.
13. Turn pump OFF.

#### CAUTION

Engaging/disengaging the water pump above LOW IDLE may result in water pump component damage and reduced service life.

14. Turn system OFF.
15. Turn engine OFF.
16. Close all drain valves and petcocks



## SECTION 4

### Recommended Support Parts

Description .....	4-1	Hydraulic Drive Motor Parts Group ....	4-3
Spray Head Parts Group .....	4-1	Monitor Parts Group .....	4-3
Control System Parts Group .....	4-2	Miscellaneous Parts Group .....	4-3
Water Pump Parts Group .....	4-2		

#### DESCRIPTION

This section contains a listing of recommended support parts that should be available in the supply warehouse. The tables are categorized by specific sub system of the MTT. **DO NOT FORGET** that all MTTs are not configured the same and there are several variations of water pumps, hydraulic drive motors, monitors and BFVs. Ensure MTT serial numbers and actual component part numbers are checked before ordering any parts. Once parts are issued from warehouse stock ensure depleted quantities are replenished to keep the recommended support parts package at 100%.

Several support parts are designated as a “**quick change assembly**” and should be used to minimize repair time of an operational MTT. Broken assemblies can be repaired by maintenance and later returned to the supply warehouse as a serviceable part.

SPRAY HEAD PARTS GROUP		
PART DESCRIPTION	PART NO.	QTY
1. Spray Head Drop-in Assembly	300409	6
2. Spray Head Diaphragm	300208	18
3. Guide Disk, Lower	300209	2
4. Guide Disk, Upper	300210	2
5. Stem Bolt	300211	2
6. O-Ring, Stem Bolt	300215	4
7. Stem Nut	300214	2
8. Bell Washer	300212	2
9. Spray Head Spring	300213	6
10. Cap Screw, SS, Housing	355335	16
11. Washer, Lock, SS, Housing	355337	16
12. Washer, Flat, SS, Housing	355336	16
13. Spray Head Deflector Ring	300216	6
14. Spray Head Deflector Ring Knob	302912	6
15. O-Ring, Base	354502	16
16. Washer, Flat (Base Plate Mount)	355295	8
17. Bolt (Base Plate Mount)	355294	8
18. Hydraulic Spray System <b>**MTT Serial No. Specific Part</b>		
a. Hydraulic Spray Head Assy. (QCA)	025610	2
b. Cylinder, Hydraulic	304744	2
c. Nut, Hex 1/2 x 20	350044	4

## SECTION 4 Recommended Support Parts

<b>B. CONTROL SYSTEM PARTS GROUP</b>		
PART DESCRIPTION	PART NO.	QTY
1. Joystick, Universal <b>**MTT Serial No. Specific Part</b>	303041	1
2. Timer, Intermittent <b>**MTT Serial No. Specific Part</b>	304751	1
3. Switch, SPST, Green Lens (Cab Control)	305019	1
4. Switch, SPST, White Lens (Cab Control)	305020	1
5. Switch, DPDT, No Lens (Cab Control)	305021	2
6. Sensor, Water Level <b>** MTT Serial No. Specific Part</b>	303822	1
7. Hydraulic Spray System <b>** MTT Serial No. Specific Part</b>		
a. Solenoid Valve, Hydraulic (Solenoid Box)	305156	2
b. Coil, 24 VDC, (Solenoid Box)	304859	2
c. Filter Element (Solenoid Box)	305276	1

<b>WATER PUMP PARTS GROUP</b>		
PART DESCRIPTION	PART NO.	QTY
1. M-4 <b>** MTT Serial No. Specific Part (QCA)</b>	304991	1
2. Ring Packing, Shaft Seal	305114	3
3. Shaft Kit	305095	1
4. Seal, Grease	304960	1
5. Ring, Snap	305103	1
6. Ring, Thrust	305104	1
7. Key, Impeller	305106	2
8. Coupling	305102	1
9. Screw, Set	305107	2
10. Seal, O-ring, Volute	305111	1
11. Wear Ring, Frame	305091	1
12. Wear Ring, Volute	305092	1
13. Washer, Impeller	305093	1
14. Bolt, Impeller	305109	1
15. Washer, Lock, Impeller	305110	1
16. Packing Gland, Set	305098	1
17. Slinger	305100	1
18. Stud, Packing Gland	305105	2
19. Nut, Packing Gland	350026	4
20. Ring, Lantern	305112	1

## SECTION 4

### Recommended Support Parts

<b>WATER PUMP DRIVE MOTOR PARTS GROUP</b>		
PART DESCRIPTION	PART NO.	QTY
1. Motor, Hydraulic (M75 30-7) <b>** MTT Serial No. Specific Part</b>	302080	1
2. Seal Kit, (M75)	300944	1
3. Flow Control Valve	300161	1

<b>MONITOR SUPPORT PARTS GROUP</b>		
PART DESCRIPTION	PART NO.	QTY
1. Joint Rebuild Kit	305141	1
2. Electric Monitor <b>** MTT Serial No. Specific Part</b>		
a. Motor, Electric	304618	1
3. Hydraulic Monitor <b>** MTT Serial No. Specific Part</b>		
a. Motor, Hydraulic	304656	1
b. Solenoid Valve (Monitor Control Valve Assembly)	304858	1
c. Solenoid Coil (Monitor Control Valve Assembly)	304859	2

<b>MISCELLANEOUS PARTS GROUP</b>		
PART DESCRIPTION	PART NO.	QTY
1. Valve, Butterfly, 3"	300030	1
2. Valve, Gate, 1.5" (Spray Bar)	300106	1
3. Valve, 3/4" Ball (Spray Bar)	300627	2
4. Seal, Coupling, 4" Dresser	300820	2
5. O-Ring, #24 (Split Flange)	354816	20

**SECTION 4**  
**Recommended Support Parts**

**NOTES**