



MHT175-CAT777-INSP-RSP-5

SPECIALTY HAULAGE SOLUTIONS FOR CONSTRUCTION AND MINING

SCHEDULED/SPECIAL INSPECTIONS & RECOMMENDED SUPPORT PARTS



MEGA CORP.®

700 Osuna Rd. N.E. • Albuquerque, NM 87113 • 1-800-345-8889 • 505-345-2661 • Fax 505-345-6190
www.megacorpinc.com

© MEGA Corp., Inc. All Rights Reserved

TABLE OF CONTENTS

Section 1	Definitions and Abbreviations	1-1
Section 2	Scheduled Maintenance Inspections	2-1
Section 3	Special Inspections	3-1
Section 4	Recommended Support Parts	4-1

TABLE OF CONTENTS

SECTION 1

Definitions and Abbreviations

Contents

Manual Usage..... 1-1	Safety Messages 1-2
Warning, Caution And Notes 1-1	Abbreviations 1-3
Use Of Shall, Will, Should And May 1-1	MHT 175 General Overview (Typical) 1-4

MANUAL USAGE

This technical manual only contains information required to safely install or service an MHT. See the appropriate Maintenance and Operators Safety Manual for specific vehicle system information and maintenance procedures. If your system is not covered in this manual please contact MEGA Corp. Product Support Group at:
 US toll free: 1-800-345-8889
 Direct: 1-505-345-2661 or visit our website at www.megacorpinc.com for more detailed contact information.

The exact location of the hazards and description of the hazards are reviewed in this section. All personnel working on or operating the MHT must become familiarized with all the safety messages.

WARNING

Due to the nature of these processes, ensure that all safety information, warnings and instructions are read and understood before any operation or any maintenance procedures are performed. Some procedures take place with heavy components and at moderate heights, ensure proper safety procedures are maintained when performing these actions. Failure to use and maintain proper safety equipment and procedures will cause injury, death or damage to equipment.

WARNING, CAUTION AND NOTES

The following definitions are found throughout the manual and apply as follows:

WARNING

Operating procedures and techniques, which could result in personal injury and/or loss of life if not carefully followed.

CAUTION

Operating procedures and techniques, which could result in damage to equipment if not carefully followed.

NOTE

Operating procedures and techniques that are considered essential to emphasize.

USE OF SHALL, WILL, SHOULD AND MAY

Shall and **Will** – Used when application of a procedure is mandatory.

Should – Used when application of a procedure is recommended.

May - Used to indicate an acceptable or suggested means of accomplishment.

SECTION 1

Definitions and Abbreviations

SAFETY MESSAGES

There are several specific safety messages on this machine. The exact location of the hazards and description of the hazards are reviewed in this section. All personnel working on or operating the machine must become familiarized with all the safety messages.

Make sure that all of the safety messages are legible. Clean the safety messages or replace the safety messages if you cannot read the words. Replace the illustrations if the illustrations are not legible. When you clean the safety messages, use a cloth, water, and soap. Do not use solvent, gasoline, or other harsh chemicals to clean the safety messages. Solvents, gasoline, or harsh chemicals could loosen the adhesive that secures the safety messages. Loose adhesive will allow the safety messages to detach.

Replace any safety message that is damaged or missing. If a safety message is attached to a part that is replaced, install a new safety message on the replacement part.

TOXIC GAS HAZARD (1)

This safety label is located on the side of the tank and at all water fill entrances.

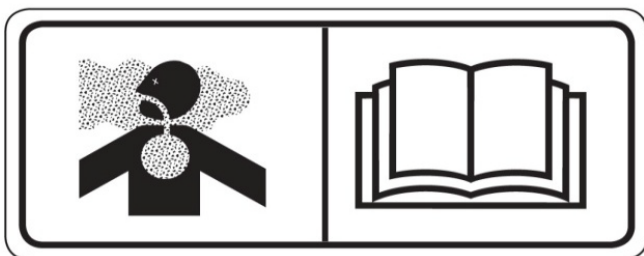

⚠ WARNING

Cutting or welding operation on the inside of the tank can cause the accumulation of toxic gases. Read and understand instructions and warnings in the Maintenance Manual. Failure to provide proper ventilation or breathing apparatus while conducting these operations may result in serious injury or death.

DO NOT OPERATE (2)

This safety label is located on the outside of the front and rear control boxes (if equipped).

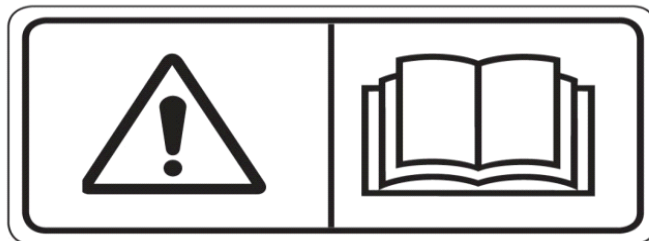

⚠ WARNING

Do not open this control box unless you read and understand the instructions and warnings in the Operator and Maintenance Manual. Failure to follow instructions or heed the warnings could result in serious injury or death.

BACKING RUNOVER HAZARD (3)

This safety label is located on the rear of the tank and inside the cab.

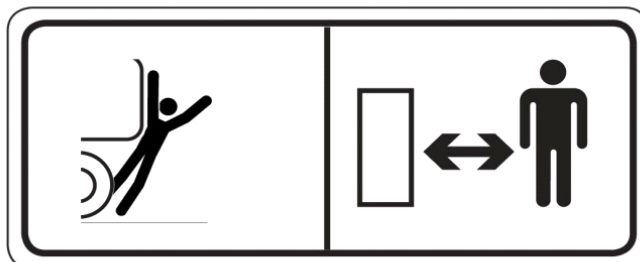

⚠ WARNING

The vehicle is equipped with a back-up alarm. Alarm must sound when operating this vehicle in reverse. Failure to maintain a clear view in the direction of travel could result in serious injury or death.

SECTION 1

Definitions and Abbreviations

FALL HAZARD (4)

This safety label is located at the top of the front and rear of the tank.

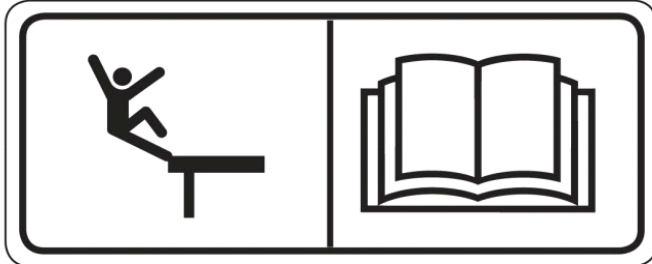

ABBREVIATIONS

e.g. - example given

FT - Feet

Kg - kilograms

l - liters

m - meters

MCH - MEGA Coal Hauler

MHT - MEGA Hauler with Truck

psi - pounds square inch

SQ FT - Square Feet

VDC - Volts Direct Current

WARNING

Do not walk on the top of tank without fall arrest PPE. Serious injury or death could occur from a fall.

HIGH PRESSURE CYLINDER (5)

This safety label is located on the hydraulic motor.

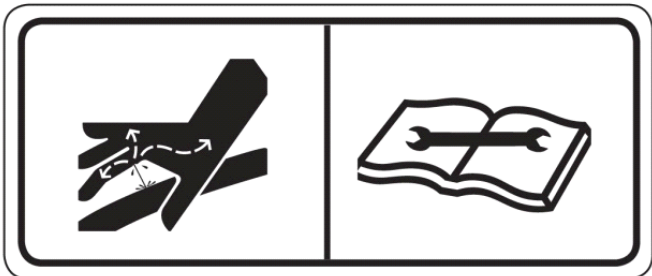

WARNING

Hydraulic cylinders and supply lines contain oil under high pressure. Improper removal and repair procedures could cause severe injury. To remove or repair, instructions in the Maintenance Manual must be followed.

SECTION 1 Definitions and Abbreviations

MHT 175 GENERAL OVERVIEW (TYPICAL)

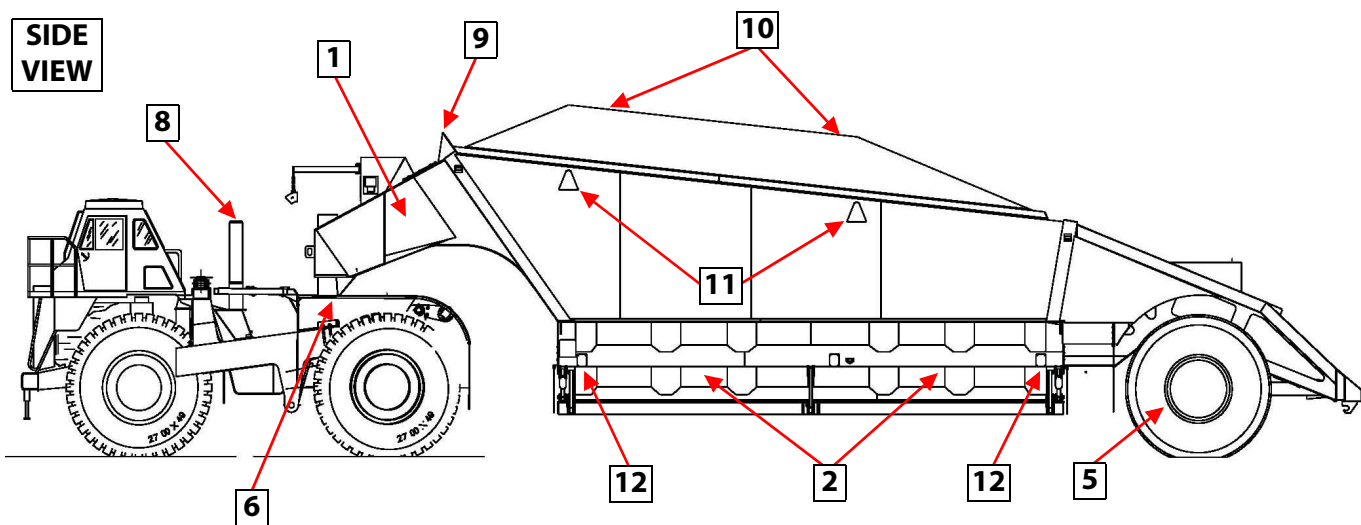
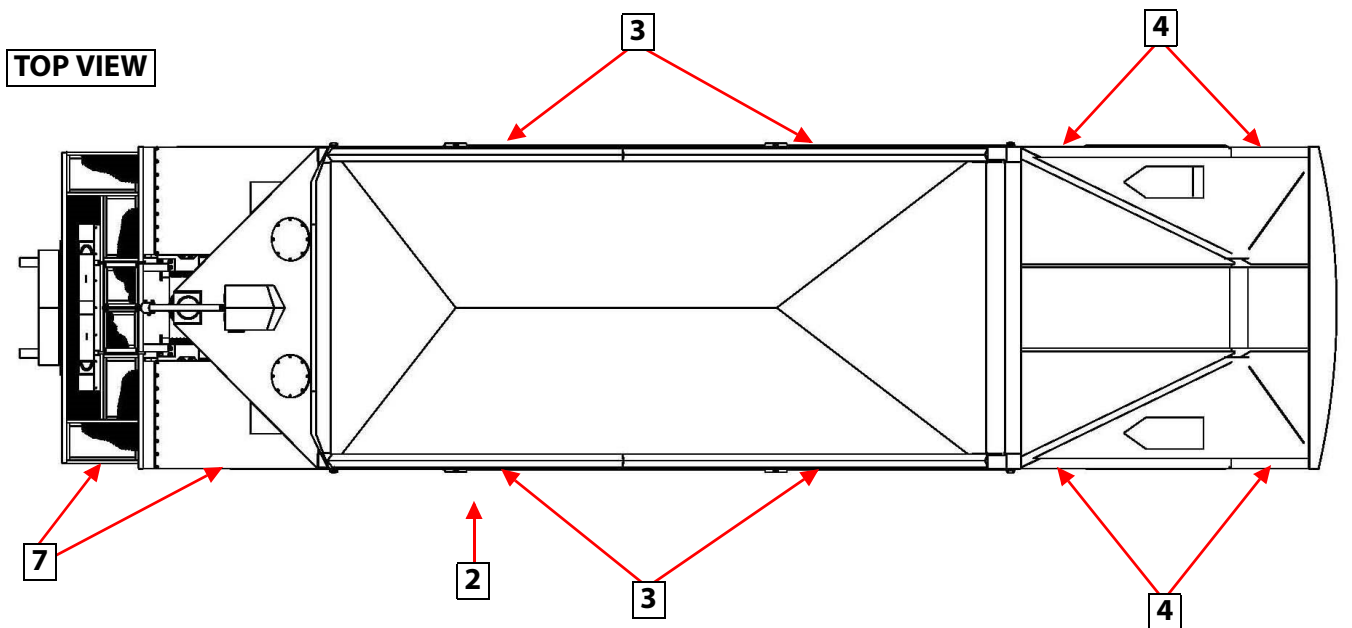

- | | |
|--|---|
| <p>1 GOOSENECK</p> <p>2 LOWER HOPPER</p> <p>3 SIDE WALL</p> <p>4 REAR BOGIE</p> <p>5 REAR AXLE & WHEEL GROUP</p> <p>6 HITCH & SADDLE</p> | <p>7 DECK & FENDER</p> <p>8 TURN LIMIT INDICATOR</p> <p>9 SPILL GUARD</p> <p>10 LOAD PROFILE</p> <p>11 END-OF-LOAD INDICATOR</p> <p>12 JACKING PADS</p> |
|--|---|

SECTION 2

Scheduled Maintenance Inspections

Contents

Description	2-1	Electrical System	2-2
Suspension & Brake System	2-1	MHT Structure & Hitch Assembly.....	2-2
Door System.....	2-2		

DESCRIPTION

This section establishes scheduled maintenance inspections of the MHT175 trailer (MHT) and associated systems at the designated frequencies. Performing these inspections will identify potential system discrepancies and allow preventative maintenance to be performed before a component or system is rendered totally inoperative. Once again, these inspections are in addition to and do not replace existing CAT scheduled inspection requirements.

		FREQUENCY				
		BI-WEEKLY (250 HRS)	MONTHLY (500 HRS)	QUARTERLY (1000 HRS)	SEMI-ANNUAL (2500 HRS)	ANNUALLY (5000 HRS)
STEP	SUSPENSION & BRAKE SYSTEM					
1	Check trailer axle and wheel group components as defined in CAT 777G Service Manual. Service individual components as required.					
2	After initial installation or and system component replacement, follow chassis required initial maintenance schedule for that component or system. Service as required.					
3	Check trailer axle struts, a-frame and pan-hard rod for security, damage and evidence of lubrication. Inspect lubrication lines for damage and security.		X			
4	Check rear axle housing and access plate for damage security and leaks. Inspect axle sump breathers for evidence of oil leakage.		X			
5	Inspect axle final drives for proper fluid level. If more than 3 Quarts (2.84 liters) are added at any inspection, remove axle inspection cover to check spindle vent cover plates security and signs of leakage. Repair as required.		X			
6	MHT rear trailing axle brake cooling components and manifolds for leaks, damage, and security.		X			
7	MHT rear bogie brake accumulators, brake valves, and slack adjusters for damage, security, and leaks.		X			
8	All brake system cooling and activation hoses for damage, security and leaks. Ensure the tractor integration points are also inspected (e.g. junction manifolds, scavenge pump, tank, SAHR, proportional group, accumulators, oil cooler union...).		X			
9	MHT bolster (side wall tunnels containing hydraulic hoses) cavity drain holes for evidence of leaking.	X				
10	Tractor brake relay for damage, security, and leaks.		X			
11	Rear axle area lube ejectors and hosing for damage, security, and leaks.		X			

SECTION 2

Scheduled Maintenance Inspections

STEP	DOOR SYSTEM	FREQUENCY				
		BI-WEEKLY (250 HRS)	MONTHLY (500 HRS)	QUARTERLY (1000 HRS)	SEMI-ANNUAL (2500 HRS)	ANNUALLY (5000 HRS)
1	Check all door cylinders for damage, security and leaks. Attaching hardware and pins for damage and evidence of lubrication.		X			
2	Check all door activation hoses for damage, security and leaks. Ensure the tractor integration points are also inspected (e.g. junction manifolds, hoist valve and tank).		X			
3	Check gooseneck components (flow divider, pressure regulator valves, counter balance valve and manifolds) for damage security and leaks.		X			
4	Check tractor integration manifolds for damage and security.				X	
STEP	ELECTRICAL SYSTEM	BI-WEEKLY (250 HRS)	MONTHLY (500 HRS)	QUARTERLY (1000 HRS)	SEMI-ANNUAL (2500 HRS)	ANNUALLY (5000 HRS)
1	Check all MHT tail and clearance lights for damage, security and proper operation.		X			
2	Check door indicator switch and cabling for damage and security.				X	
3	Check MHT rear trailing axle electrical junction box for damage and security. Inspect all wire terminals strips for security.		X			
4	Check gooseneck electrical cabling for damage and security from the boom collar to the tractor integration point.		X			
5	Check electric turn limit indicator, lights, backup alarms, cab light/alarm assembly for damage, security and proper operation.	X				
STEP	MHT STRUCTURE & HITCH ASSEMBLY	BI-WEEKLY (250 HRS)	MONTHLY (500 HRS)	QUARTERLY (1000 HRS)	SEMI-ANNUAL (2500 HRS)	ANNUALLY (5000 HRS)
1	Check MHT rear axle mounting structure and upper rear deck for damage and cracks.		X			
2	Check MHT rear bumper assembly for damage, security and cracks.		X			
3	Check lower hopper assembly and dump doors for security, damage and cracks.			X		
4	Check all MHT interior and exterior walls for damage and cracks.			X		
5	Check gooseneck assembly for damage and cracks. Inspect gooseneck turn limit cheeks for evidence of turn limit indicator contact. Repair as required.				X	
6	Check ball hitch skirt assembly for damage, security and cracks.			X		
7	Remove ball skirt and inspect upper retention plate for broken bolts and evidence of spherical ball contact with the upper retention plate. Ensure upper spherical ball shows evidence of lubrication.				X	
8	Check clearance between hitch spherical ball and upper brass bushing. If gap is more than 0.010" shim upper brass bushing as described in the MHT175 Field Installation Manual.				X	
9	Check tractor fender assemblies for damage, security and cracks				X	

SECTION 2

Scheduled Maintenance Inspections

STEP	MHT STRUCTURE & HITCH ASSEMBLY (CONTINUED)	BI-WEEKLY (250 HRS)	MONTHLY (500 HRS)	QUARTERLY (1000 HRS)	SEMI-ANNUAL (2500 HRS)	ANNUALLY (5000 HRS)
10	Check hitch receiver and saddle assembly mounts for damage and security. Inspect pivot pins and hitch clamp assemblies for security.				X	
11	Check tractor fender assemblies for damage, security and cracks				X	
12	Check deck assembly for damage, security and cracks. Inspect deck mounts for cracks and mounting bolts for security.			X		
13	Check turn stop indicator for damage, security and cracks. Inspect chassis rail mount plates for cracks and all mounting hardware for security.			X		

SECTION 2
Scheduled Maintenance Inspections

SECTION 3 Special Inspections

Contents

Description	3-1
Turn Limit Indicator Contact	3-1

DESCRIPTION

This section contains special inspection requirements for exceeding an establish system limit. The established inspections are designed to reveal any damage sustained and determine serviceability of the MHT175 system.

TURN LIMIT INDICATOR CONTACT

The metal turn limit indicator is designed to provide a visual indication to the operator they have reached the maximum rotation of the MHT. This is noted by the gooseneck cheek contacting the turn limit indicator as shown below.

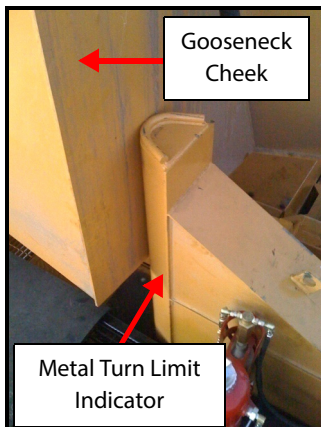

When the system experiences high impact loads damage may occur to both the gooseneck cheek plates and the turn limit indicator. The gooseneck cheek plates may buckle or begin to weaken and eventually cause further damage to adjoining gooseneck plate structure. The turn limit indicator may experience excessive bending moments and begin to tear or weaken lower mount plate and horse collar welds.

INSPECTION

1. Remove a gooseneck access cover.
2. Check gooseneck cheek structure for damage. Inspect welds for evidence of cracking and metal plates for signs of buckling.

3. Check adjoining gooseneck interior and exterior structure for damage. Inspect gooseneck structure and plating for weld cracking and evidence of steel plate buckling.
4. Check turn limit indicator for damage. Inspect plates and welds for cracks and deformities.
5. Check turn limit indicator deck and horse collar mounts for damage. Inspect rail mounting plates and angle brackets for cracks and loose hardware.

Contact MEGA Product Support at: 1-800- 345-8889 for any major structural repair issues.

HITCH BALL OVER OSCILLATION

The hitch ball assembly is designed to oscillate 12 degrees within the lower socket assembly as shown below. This allows the MHT175 a large range of motion when operating in the pit, on haul road, on coal piles and when unloading the trailer (MHT).

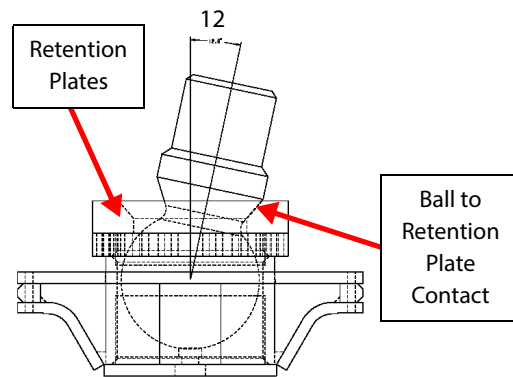
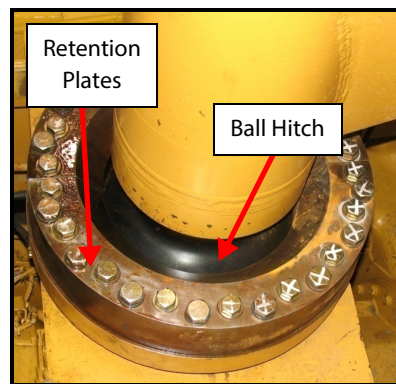

SECTION 3

Special Inspections

When operating the MHT175 beyond the allowable 12 degree limit, the ball will contact the upper retention plate and potentially damage several components of the system. Repeated and hard contacts will damage upper retaining plates, upper brass bushings, mount bolts and in severe cases cause structural damage to the gooseneck, ball hitch tube, and hitch receiver upper mount plate.

INSPECTION

1. Remove hitch ball skirt assembly.
2. Check for broken bolts on the upper retaining plate. If mount bolts are missing, have been sheared off or laying on the lower receiver, severe contact has occurred.
3. Check upper retaining plates and hitch ball for damage. Inspect retaining plates and hitch ball for evidence of hard contacts as shown below.

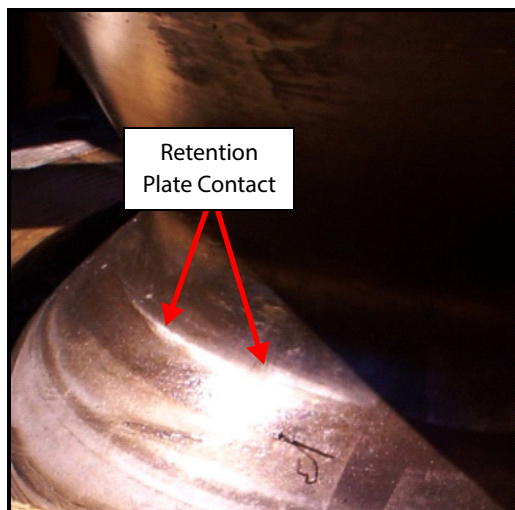
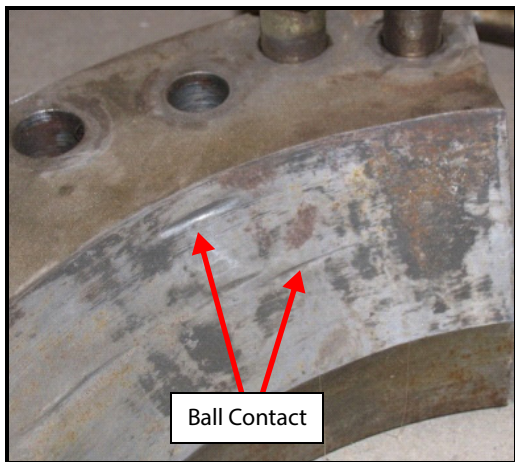

4. If hard contact is confirmed, remove upper retention plates and inspect the upper retention plates, brass bushings and lower receiver as follows:

- a. Inspect upper retention plates for mushrooming of flat mating ends. Lay the retention plate on a flat surface and check for warpage. If retention plate is mushroomed or warped the retention plate set must be replaced.

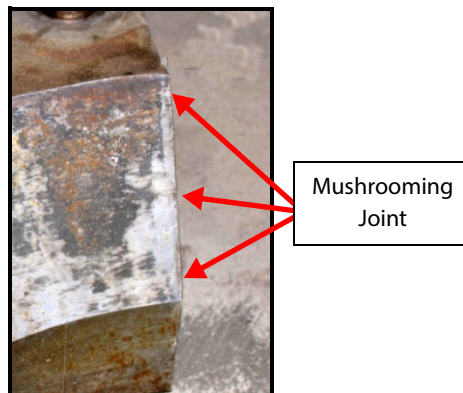

- b. Check upper brass bushings for over oscillation ball contact as shown below. If contacted and deformed replace upper bushing set.



SECTION 3

Special Inspections

- c. Inspect lower receiver assembly for elongated/pulled upper retention plate bolt holes and deformation of the lower receiver mount ring as shown below. If either condition is noted, contact Mega Product Support to determine if the receiver can be refurbished or if a replacement is required.

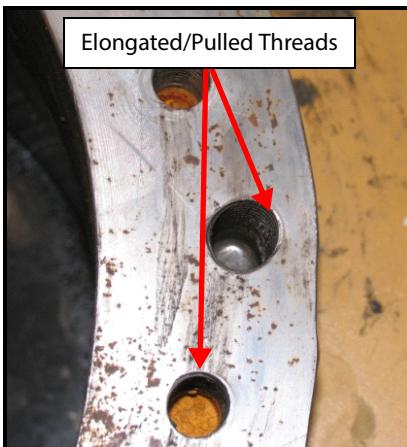
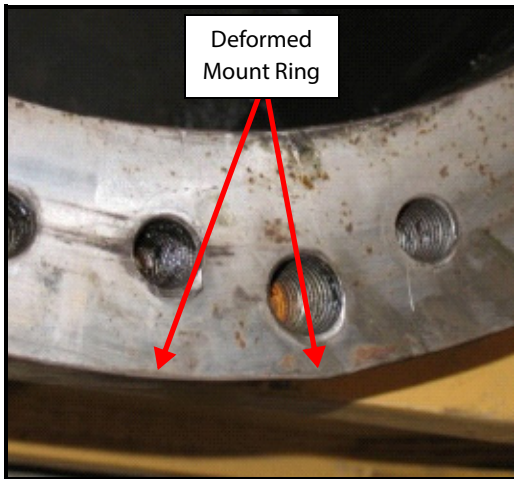

5. Check interior and exterior gooseneck structure and plating for damage. Inspect gooseneck structure and plating for weld cracking and evidence of steel plate buckling. If either condition is noted contact MEGA Product Support at: 1-800-345-8889.

SECTION 3
Special Inspections

SECTION 4

Recommended Support Parts

Contents

Description	4-1	Hitch Assembly Parts Group	4-1
Door System Parts Group	4-1	Miscellaneous Parts Group	4-2
Brake System Parts Group	4-1		

DESCRIPTION

This section contains a listing of recommended support parts that should be available in the supply warehouse. The tables are categorized by specific sub system of the MHT. **DO NOT FORGET** that all MHTs are not configured the same and there are several variations of hydraulic systems, door cylinder configurations and turn limit indicators. Ensure MHT serial numbers and actual component part numbers are checked before ordering any parts. Once parts are issued from warehouse stock ensure depleted quantities are replenished to keep the recommended support parts package at 100%.

A. DOOR SYSTEM PARTS GROUP

PART DESCRIPTION	PART NO.	QTY
1. Cylinder, Hyd. *MHT Serial No. Specific Part (4 Cylinder Config)	302829	1
2. Valve, Counterbalance (Door Close Circuit)	305323	1
3. Switch, Limit	305927	1
4. Bushing, Rexnord (Door Pivot)	354368	12

B. BRAKE SYSTEM PARTS GROUP

PART DESCRIPTION	PART NO.	QTY
1. Temp Sensor (7N-7854)	303189	1
2. O-Ring, 115 (Temperature Sensor)	303192	1

C. HITCH ASSEMBLY PARTS GROUP

PART DESCRIPTION	PART NO.	QTY
1. Shim Set 18" Ball (Ball Hitch)	038904	1
2. Screw, Cap 1" x 5.5"	350433	4
3. Washer, Flat 1"	350009	4
4. Screw, Cap 7/8" x 5.5"	350400	4
5. Washer, Flat 7/8"	350008	4

SECTION 4
Recommended Support Parts

D. MISCELLANEOUS PARTS GROUP		
PART DESCRIPTION	PART NO.	QTY
1. Seal, O-ring -20	354815	8
2. Seal, O-ring -24	354816	6
3. Seal, O-ring -32	354817	6
4. Seal, O-ring -40	354818	2
5. Light, Work, 24 VDC	300777	1
6. Light, LED, Clearance, Red	355374	1
7. Light, LED, Clearance, Amber	355375	1

If your system is not covered in this manual or are having difficulties locating the necessary components please contact MEGA Corp. Product Support Group at:

US Toll Free: 1-800-345-8889 or

Direct: 1-505-345-2661 or visit our website at www.megacorpinc.com for more detailed contact information.